



VILLA PERGOLA VILLA PERGOLA

Avec sa construction simple, la Villa Pergola s'assemble facilement et rapidement. De plus, l'utilisation de l'aluminium offre une durabilité à long terme tout en minimisant l'entretien.

With its simple construction, the pergola Villa assembles easily and quickly. Also, the use of aluminum provides long term durability while minimizing maintenance.

HAUTEUR | HEIGHT 8' (250 cm)

| | |
|--------------------------|---------------------------------------|
| *DIMENSIONS DIMENSIONS | 10'x10' 10'x13' 13'x13' 19'x13' |
| PERSIENNES LOUVERS | 135 x 30 x 1.2 mm |
| POTEAUX BEAMS | 127 x 127 x 2 mm |

* Les dimensions impériales sont approximatives (voir pages suivantes)

* The imperial dimensions are approximate (see following pages)

Options additionnelles: • Pergola manuelle

Additional options:

• Pergola automatisée

• Moustiquaire manuelle

* • Moustiquaire automatisée

* • Panneau d'intimité

• Manual pergola

• Automated pergola

• Manual pergola screen

• Automated pergola screen

• Intimty panel

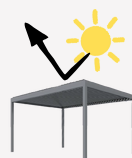

BLANC - CHARBON - HYBRIDE
WHITE - CHARCOAL - HYBRID

* Consulter la fiche technique individuelle

* Consult the individual technical sheet



Courriel
info@procamdistribution.ca

Site web
www.procamdistribution.ca

Téléphone
1-844-776-2266

Adresse
780 rue Vernon Suite D
Gatineau (Québec) J9J 3K5

PIÈCES
PIECES

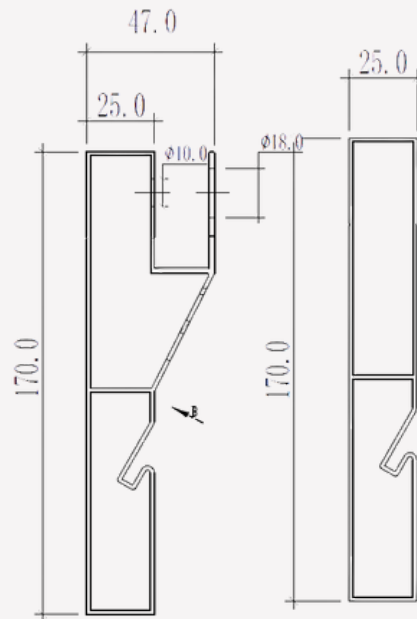

MOTEUR TÉLÉSCOPIQUE
TELESCOPIC ENGINEER

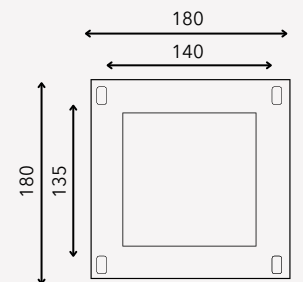
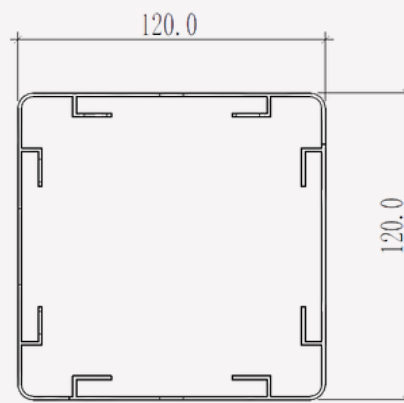
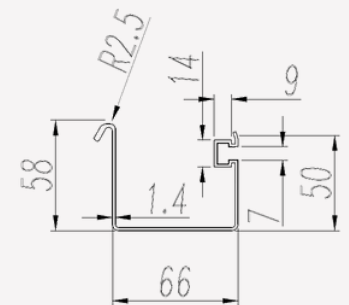

Épaisseur ± 7 mm
Thickness ± 7 mm

DÉTAIL PLAQUE ANCRAGE
GROUND ARTICULATION DETAIL

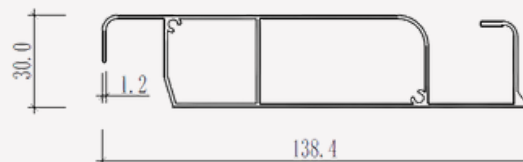

 Courriel
info@procamdistribution.ca

 Site web
www.procamdistribution.ca

 Téléphone
1-844-776-2266

 Adresse
780 rue Vernon Suite D
Gatineau (Québec) J9J 3K5



10' x 10'
(300 cm x 300 cm)

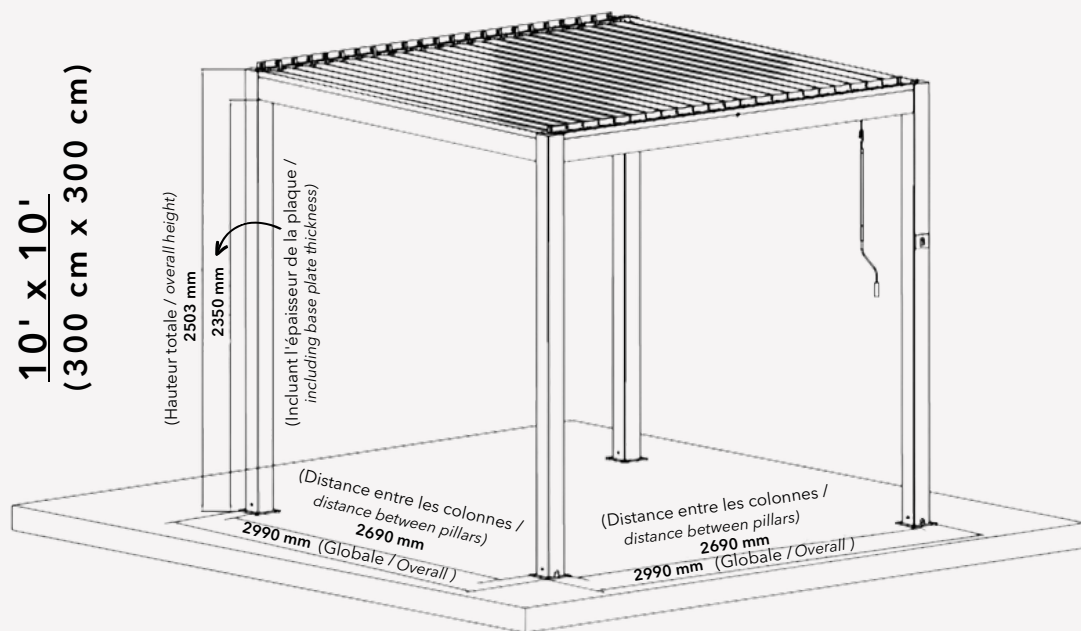

10' x 13'
(300 cm x 400 cm)

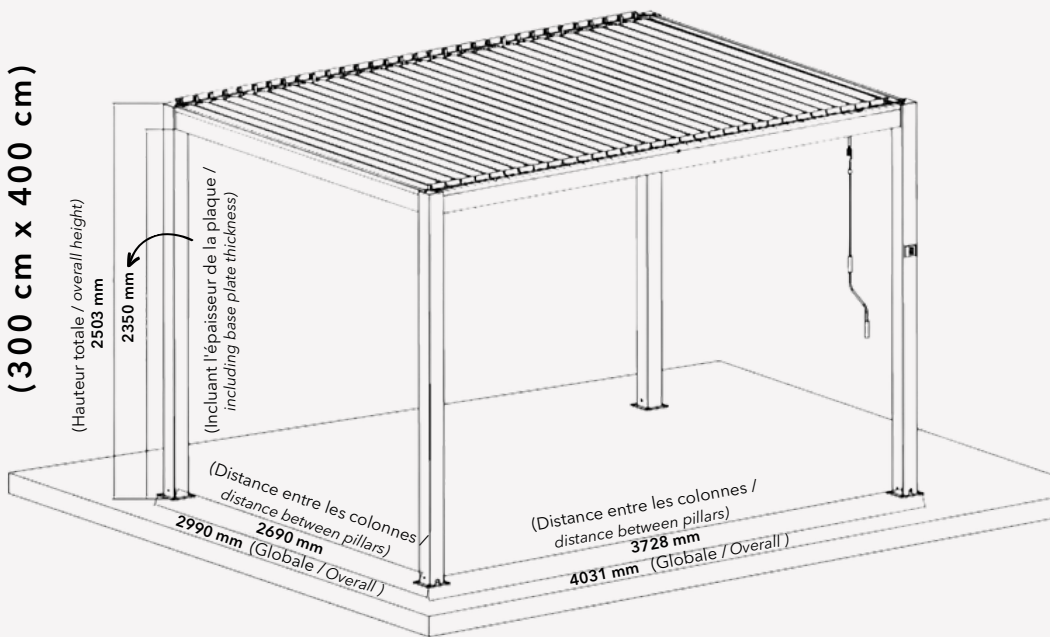

13' x 13'
(400 cm x 400 cm)

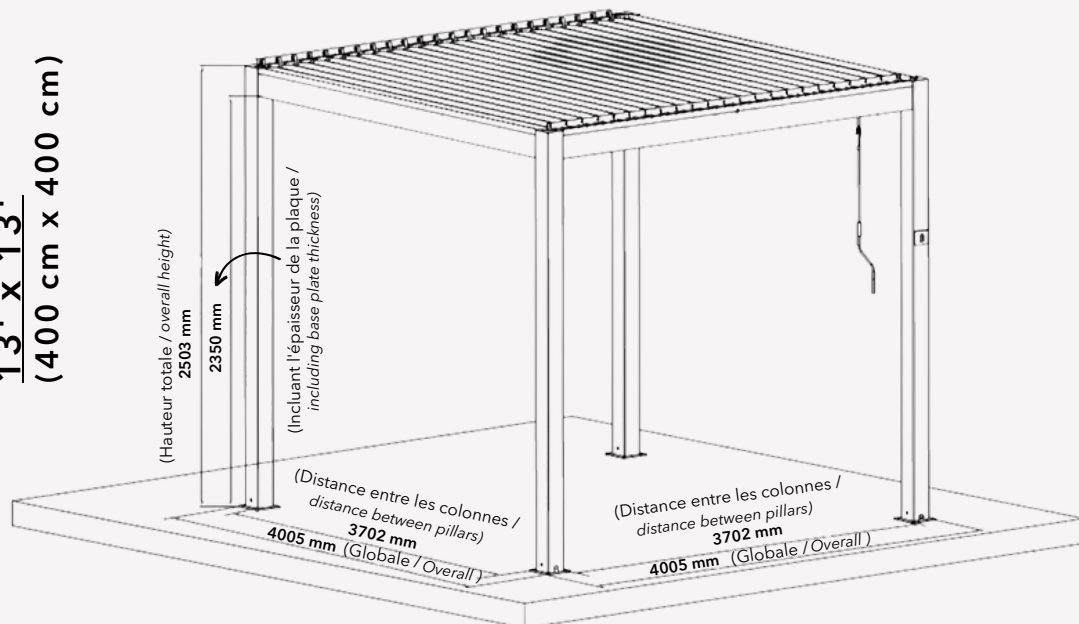

 Courriel
info@procamdistribution.ca

 Site web
www.procamdistribution.ca

 Téléphone
1-844-776-2266

 Adresse
780 rue Vernon Suite D
Gatineau (Québec) J9J 3K5



10' x 10'
(300 cm x 300 cm)

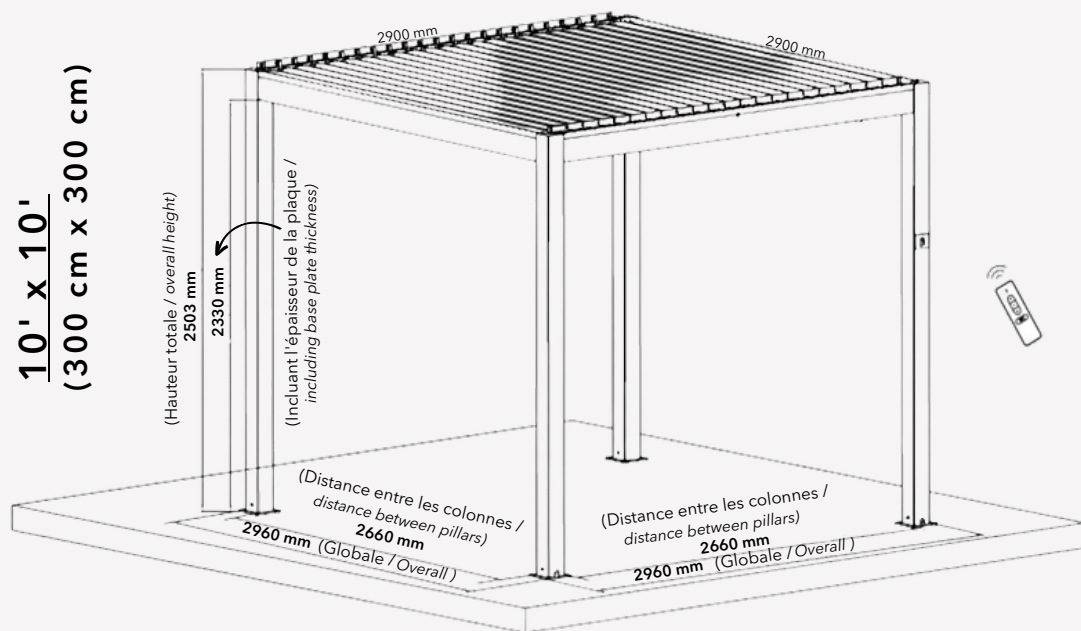

10' x 13'
(300 cm x 400 cm)

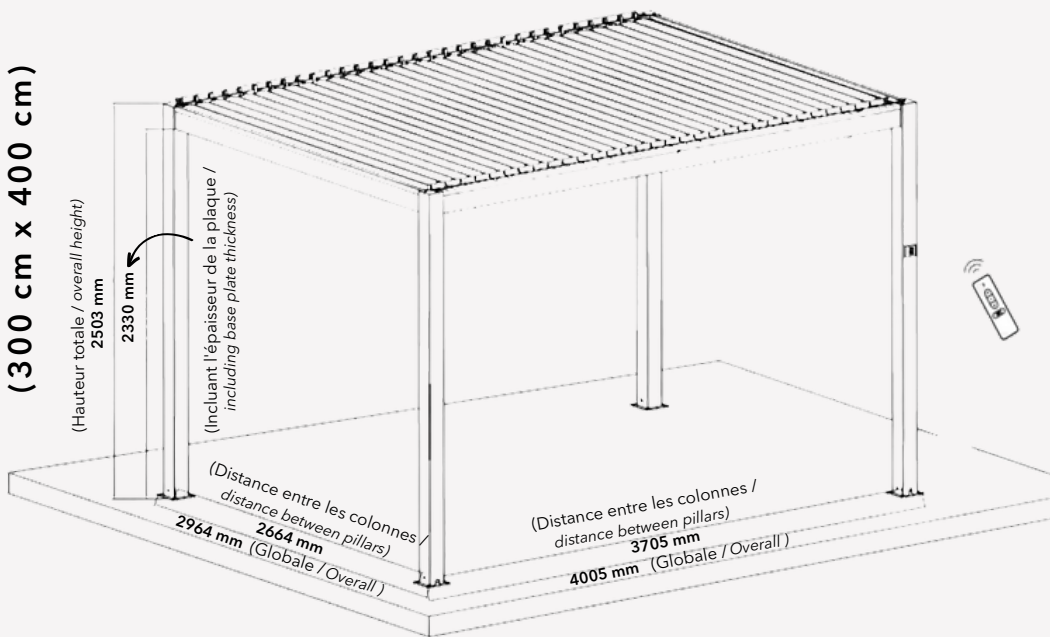

13' x 13'
(400 cm x 400 cm)

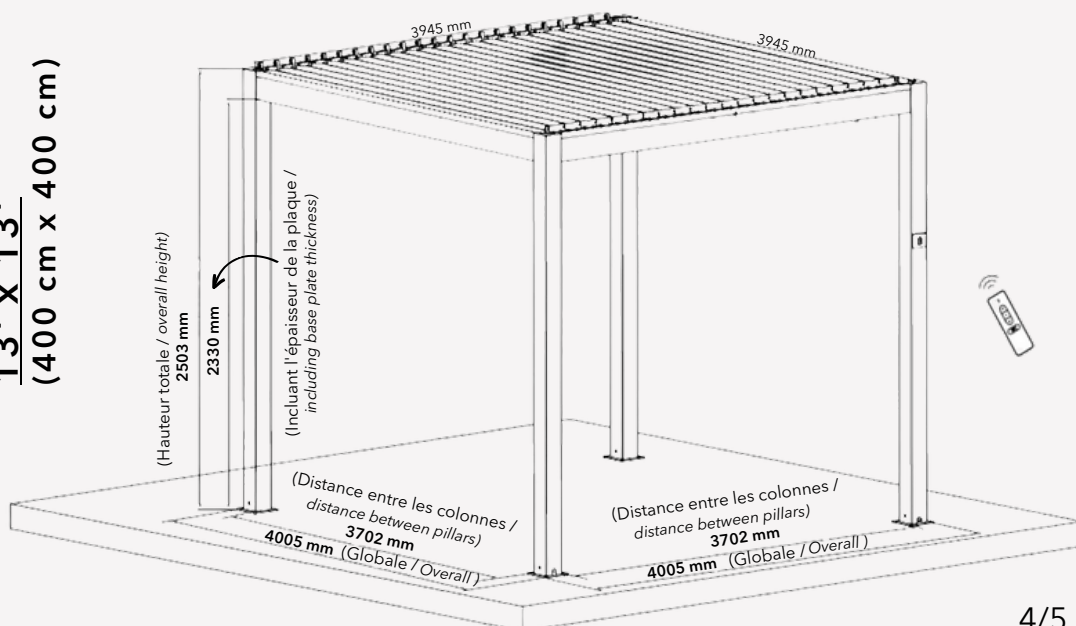

✉ Courriel
info@procamdistribution.ca

🌐 Site web
www.procamdistribution.ca

📞 Téléphone
1-844-776-2266

📍 Adresse
780 rue Vernon Suite D
Gatineau (Québec) J9J 3K5

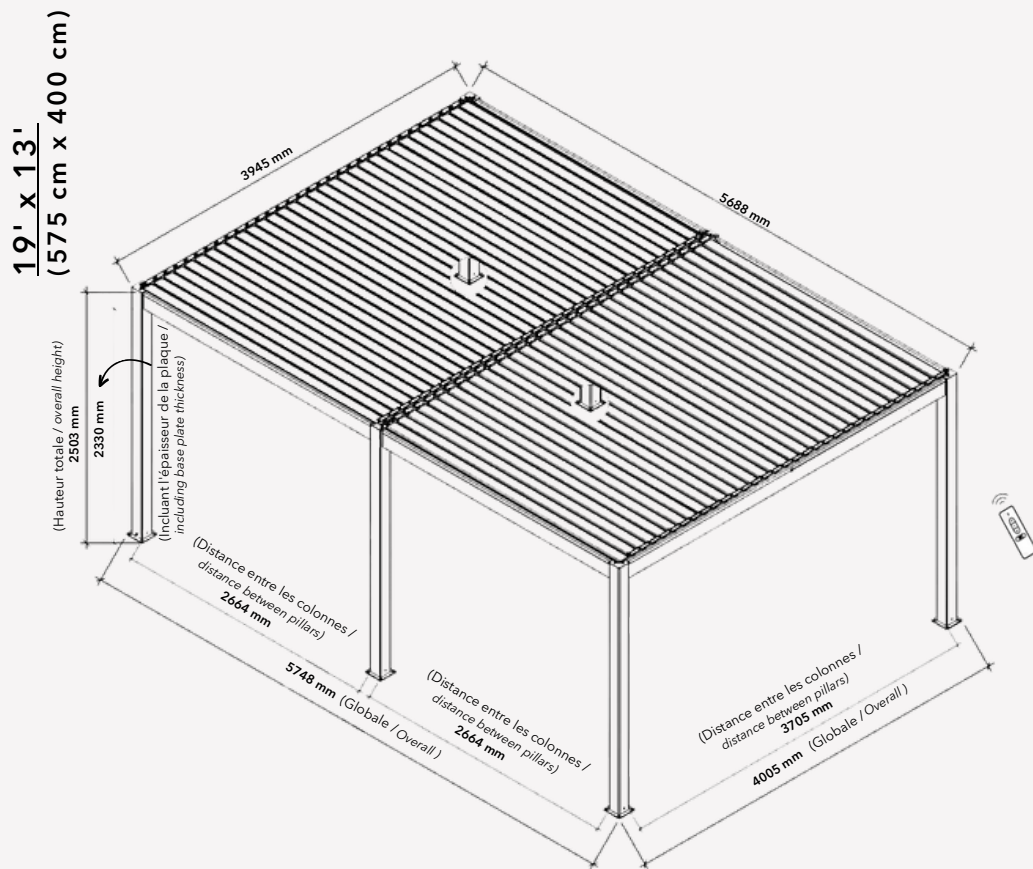

 Courriel
info@procamdistribution.ca

 Site web
www.procamdistribution.ca

 Téléphone
1-844-776-2266

 Adresse
780 rue Vernon Suite D
Gatineau (Québec) J9J 3K5