

PERGOLA MONACO 2.0
2.0 MONACO PERGOLA

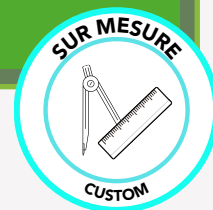

La pergola bioclimatique Monaco est reconnue pour son élégance, sa robustesse et son design urbain. Elle est conçue en aluminium afin de résister aux changements climatiques sévères et aux vents allant jusqu'à 100 km/h. *(La résistance n'est pas garantie sous le poids de la neige)*

The Monaco bioclimatic pergola is recognized for its elegance, robustness and urban design. It is designed in aluminum to withstand severe weather changes and winds up to 100 km/h. *(The resistance is not guaranteed under the weight of the snow)*

- Options additionnelles:
Additional options:
- Moustiquaire manuelle
Manual pergola screen
 - Moustiquaire motorisée
Motorized pergola screen
 - Panneau d'intimité
Intimty panel

Portée maximale: 4,5m x 6m
Maximum range: 4,5m x 6m

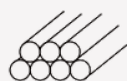

100% ALUMINIUM
100% ALUMINUM



ANGLE RÉGLABLE
ADJUSTABLE ANGLE



RÉSISTANCE AU VENT (100 km/h)
WIND RESISTANCE (100 km/h)



CHARGE DE NEIGE (100 kg/m²)
SNOW LOAD (100 kg/m²)



ÉTANCHE
WATERPROOF

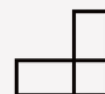

MODULAIRE
SPLICABLE



BLANC
WHITE



CHARBON
CHARCOAL



GRIS PALE
LIGHT GRAY



BRUN
BROWN

* D'AUTRES COULEURS SPÉCIALES PEUVENT ÊTRE PERSONNALISÉES

* OTHER SPECIAL COLORS CAN BE CUSTOMIZED



 Courriel
info@procamdistribution.ca

 Site web
www.procamdistribution.ca

 Téléphone
1-844-776-2266

 Adresse
780 rue Vernon
Gatineau (Québec) J9J 3K5

DESCRIPTION

- 1 BAR DE TRANSITION
COUPLING LEVER
- 2 COUVERTURE DE POUTRE
BEAM COVER
- 3 BLOC DE CONNECTION EN ALUM.
CONNECTING METAL BLOCK
- 4 POUTRE
BEAM
- 5 COLONNE DE SUPPORT
STAND COLUMN
- 6 MOTEUR TÉLÉSCOPIQUE
TUBULAR MOTOR
- 7 GOUTTIÈRE INTÉGRÉE
BUILT-IN SINK
- 8 SILICONE ÉTANCHE (NON INCLUS)
WATERPROOF SILICONE (NOT INCLUDED)
- 9 PERSIENNES
LOUVER
- 10 BLOC DE CONNECTION EN ALUM.
CONNECTING METAL BLOCK
- 11 PLAQUE DE BASE
BASE PLATE
- 12 HAUTEUR PAR DÉFAUT: 2.7M
DEFAULT HEIGHT: 2.7M

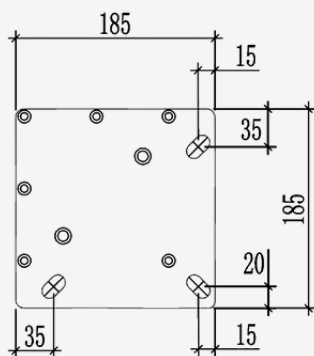
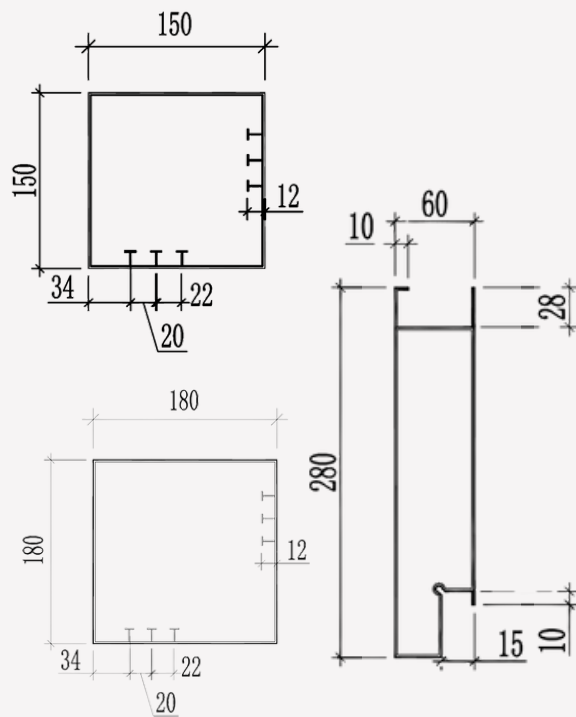
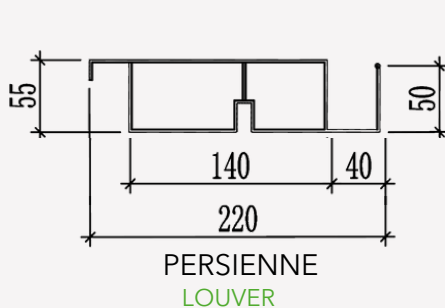
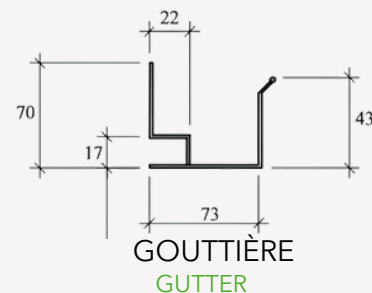
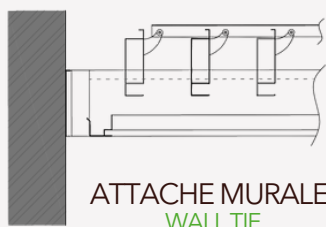
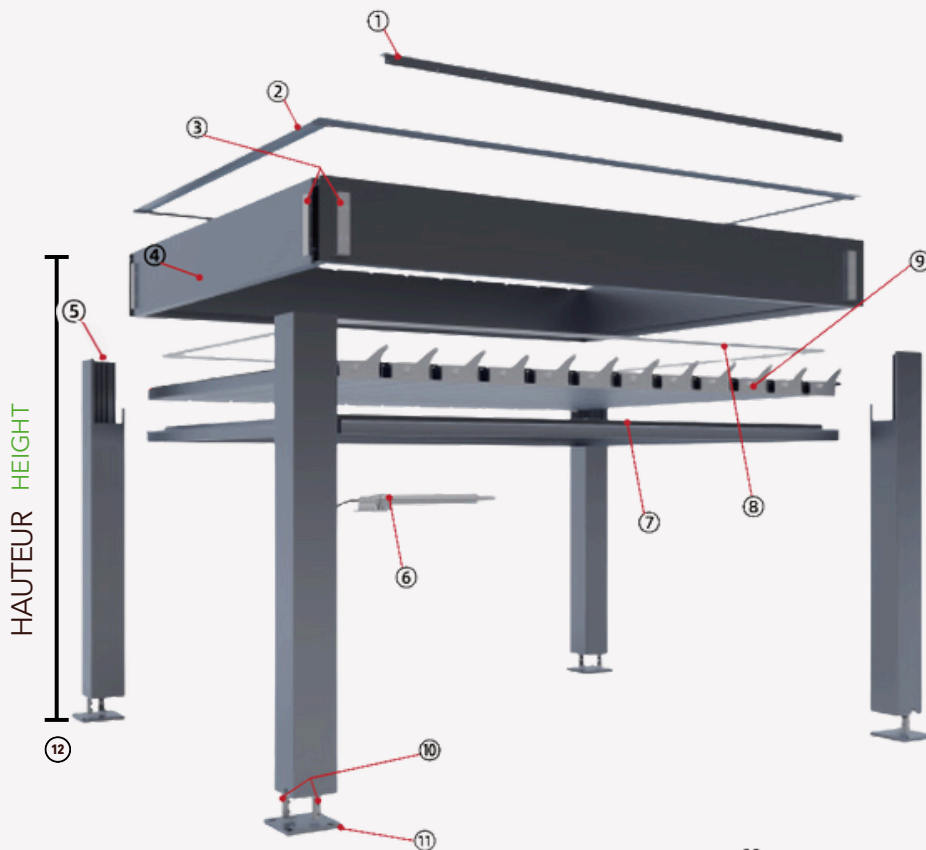

PLAQUE ANCRAGE: 15 MM
GROUND ARTICULATION: 15 MM

COLONNE
COLUMN

✉ Courriel
info@procamdistribution.ca

🌐 Site web
www.procamdistribution.ca

📞 Téléphone
1-844-776-2266

📍 Adresse
780 rue Vernon
Gatineau (Québec) J9J 3K5